

# L/CERTIFIED BY LEXUS



---

WARRANTY SUPPLEMENT AND  
ROADSIDE ASSISTANCE GUIDE

# L/CERTIFIED BY LEXUS

WARRANTY

CONTENTS

SUPPLEMENT

Welcome to the Lexus Family	3
L/Certified Vehicle Preparation	4
How to Get Assistance	5
Special Services	6
Complimentary First Oil Change and Service	6
Loaner Car Program and Travel Protection	6
Roadside Assistance Protection and Towing	6
L/Certified Limited Warranty	7
Protect Your Lexus Against Corrosion	12
Lexus Key Replacement	13
Safety Belt Information	14
Roadside Assistance Protection	15
National Service History Database	17
Service Maintenance Record	18
Body Inspection	25

LIMITED WARRANTY, MAINTENANCE, AND GENERAL INFORMATION

WARRANTY  
SUPPLEMENT

L/CERTIFIED LIMITED WARRANTY REGISTRATION

PRE-OWNED PURCHASE DATE

Month Day Year

Mileage

Vehicle Identification Number

Customer Name

Dealer Code

WARRANTY PERIOD

The coverage under this warranty begins (a) at the expiration of the Basic Warranty, or (b) at the vehicle purchase date, whichever occurs later, and remains in effect until the earlier of two years, or the date on which you transfer your Lexus to a subsequent owner, whichever comes first (the "Warranty Period"). Mileage is unlimited.

CERTIFIED LIMITED WARRANTY EXPIRES

Month Day Year

DEALER INFORMATION

Name

City State

Dealer Code

Certification Number

## L/CERTIFIED BY LEXUS

WARRANTY

SUPPLEMENT

### THE WARRANTY SUPPLEMENT TO YOUR VEHICLE OWNER'S MANUAL AND OWNER'S GUIDE

Keep this *Supplement* in your vehicle. In this *Supplement* you will find the L/Certified Limited Warranty, Roadside Assistance information, and facts about Lexus parts and service.

- Warranty information is provided to protect your investment with an outline of procedures for solving almost any problem you may have with your pre-owned Lexus. Additional important powertrain warranty information is found in your *Owner's Guide*. Your *Owner's Manual* also contains important information; be sure to read it carefully.

- All information, including the terms and conditions of the L/Certified Limited Warranty, is based on the latest data available at the time of publication and is subject to change without notice.
- Please be aware that any modification to your Lexus could affect its performance, safety, or durability and will void your L/Certified Warranty.

## L/CERTIFIED BY LEXUS

### WELCOME TO THE LEXUS FAMILY

#### WARRANTY

#### SUPPLEMENT

The entire Lexus organization would like to take this opportunity to thank you for purchasing your L/Certified Pre-Owned vehicle.

This highly sophisticated vehicle is a statement in itself of your desire to own a Lexus that offers uncompromising automotive engineering, design, luxury, and quality.

Your Lexus is the culmination of more than fifty years of automotive research and development by Toyota Motor Corporation. We want you to achieve the optimum satisfaction with your purchase of this high-performance luxury automobile. To better ensure this level of satisfaction, please invest a small amount of time to:

- Read and carefully consider the recommendations contained in this *Supplement*, the original *Owner's Guide*, and the *Owner's Manual*.

- Bring your vehicle to an authorized Lexus dealership for the maintenance recommendations contained in the *Owner's Manual*.

Please accept our best wishes for many years of pleasurable and safe driving in your L/Certified Pre-Owned Lexus.

Andrew Gilleland  
Group Vice President & General Manager  
Lexus Division  
Toyota Motor North America

# L/CERTIFIED BY LEXUS

WARRANTY

SUPPLEMENT

## L/CERTIFIED VEHICLE PREPARATION

### TEAMWORK IN QUALITY

Each L/Certified vehicle is subjected to a 161-point inspection and quality check before it is offered for sale at your Lexus dealership. Preparing your Lexus is a team effort between Lexus and your dealership's Sales and Service Departments to ensure that each L/Certified Pre-Owned vehicle meets Lexus's exacting standards for mechanical quality and physical appearance.

## L/CERTIFIED BY LEXUS

This Lexus Certified Pre-Owned vehicle has undergone a battery of inspections and has been prepared to Lexus mechanical and appearance standards.



VEHICLE IDENTIFICATION NUMBER

CERTIFICATION #

THE FOLLOWING CHECKLIST ENSURES THAT THIS VEHICLE HAS PASSED ALL REQUIRED INSPECTIONS:

- 161-point mechanical inspection
- Mechanical re-conditioning to Lexus standards
- Appearance re-conditioning to Lexus standards
- CARFAX<sup>SM</sup> vehicle history report with no title/lien results

SALES DELIVERY CHECKLIST

- Complete final paper-work
- Explain the following items:
  - Review all features and controls
  - Review warranty and maintenance schedule
  - Review Owner's Plus file(s) contents
  - Review optional Lexus Key System
  - Review floor mat proper installation and care
- Review and Customer Care provisions
- Schedule First Complimentary Service

Service Manager \_\_\_\_\_

Sales Representative \_\_\_\_\_

### INSPECTION CERTIFICATE

SALES 000001

0000 0000 01

## L/CERTIFIED BY LEXUS

### HOW TO GET ASSISTANCE

#### WARRANTY

#### SUPPLEMENT

### CUSTOMER SATISFACTION

Your satisfaction with your Lexus vehicle and your Lexus dealership is extremely important to every member of the Lexus family, whether they are located at your dealership, area office, or national headquarters. We are committed to providing the finest vehicles supported by the best customer service.

However, we do realize that misunderstandings may occur, questions may be left unanswered, or expectations may not be met completely. If such incidents occur, we would like to provide assistance in the following manner:

#### LEXUS DEALERSHIP MANAGEMENT

Normally, any misunderstandings can be resolved by involving the appropriate dealership department manager. If you feel further review is required, the owner and/or general manager of your Lexus dealership should be involved.

**Lexus Brand Engagement Center**  
**1-800-25-LEXUS** (1-800-255-3987)

For TDD only: 1-800-443-4999

Customer Satisfaction representatives are available to you by calling our toll-free number. They can provide product information, answer questions, assist in settling misunderstandings that are not resolved with your Lexus dealership management, or assist you with any questions you may have regarding this warranty.

If you would prefer to write, our address is:

Lexus Brand Engagement Center  
P.O. Box 259001  
Mail Drop E3-D2  
Plano, TX 75025-9001

When traveling in Canada,\* you can contact Lexus directly at 1-800-265-3987.

Whether calling or writing, please provide the following information:

- Vehicle Identification Number (VIN), the 17-digit number set forth at the beginning of this warranty and also located on the dash of your vehicle
- Current vehicle mileage
- The names of your selling and servicing dealers
- Your daytime and evening telephone numbers

\* Roadside Assistance is not available in Mexico.

## L/CERTIFIED BY LEXUS

### WARRANTY

### SPECIAL SERVICES

### SUPPLEMENT

In addition to the terms of the L/Certified Warranty, Lexus is proud to provide the following services and benefits to our L/Certified Pre-Owned customers as another indication of our commitment to quality service for our vehicle owners.

#### COMPLIMENTARY MAINTENANCE

Your Lexus dealer has been specially trained and equipped to maintain your vehicle better than anyone else. We are proud to stand behind this claim by including complimentary maintenance for 2 years or 20,000 miles, whichever comes first. Service intervals occur every 5,000 miles or every 6 months, whichever occurs first.

Your complimentary maintenance begins the day you purchase or lease your vehicle and covers factory recommended maintenance services that occur during the time your coverage is active. At each covered service, Lexus-trained technicians will perform the services as outlined in the Scheduled Maintenance Log section of your Lexus Warranty and Services Guide under normal driving conditions. Services recommended under special operating conditions may be provided at extra cost. Please see your *Owner's Manual* for specific maintenance information for your automobile.

#### LOANER CAR PROGRAM

If your vehicle is required to stay overnight at the dealership Service Department because of a warrantable condition requiring longer than eight (8) hours to repair, Lexus will provide you with a loaner vehicle for a maximum of five (5) days (up to \$50 per day).

#### TRAVEL PROTECTION

If necessitated by an emergency warrantable condition, Lexus will provide overnight lodging and meals up to a maximum of three (3) nights (up to \$200 per night) and substitute transportation up to a maximum of five (5) days (up to \$50 per day) under the following circumstances:

- Your vehicle down time exceeds eight (8) hours and
- Your home is more than 100 miles from the Lexus dealer performing the repair.

Reimbursement for lodging and meal expenses and substitute transportation can be arranged by contacting your Lexus dealership's Service Consultant for assistance.

#### ROADSIDE ASSISTANCE PROTECTION

Roadside Assistance Protection will be provided for two years from the expiration of the Basic Warranty or from the vehicle purchase date, whichever occurs later. Mileage is unlimited.

#### TOWING

Towing charges to the nearest authorized Lexus dealer will be reimbursed if necessitated by a warrantable vehicle condition.

Roadside Assistance or towing services are readily available by calling: **1-800-25-LEXUS** (1-800-255-3987).

Details about this service are found in the Roadside Assistance Protection section of this *Supplement*. Roadside Assistance coverage is available in the continental U.S. and Canada.



## L/CERTIFIED BY LEXUS

### L/CERTIFIED LIMITED WARRANTY

#### WARRANTY

#### SUPPLEMENT

#### WARRANTOR

Your L/Certified Limited Warranty is provided by Lexus, a division of Toyota Motor Sales, Inc., U.S.A., and Toyota Motor Insurance Services, Inc.

#### WARRANTY PERIOD

The coverage under this warranty begins (a) at the expiration of the Basic Warranty, or (b) at the vehicle purchase date, whichever occurs later, and remains in effect until the earlier of two years, or the date on which you transfer your Lexus to a subsequent owner, whichever comes first (the "Warranty Period"). Mileage is unlimited. **This warranty is not transferable to any subsequent owner. THIS WARRANTY IS NULL AND VOID IN ALL RESPECTS IF YOU PURCHASED YOUR LEXUS FROM ANYONE OTHER THAN AN AUTHORIZED LEXUS DEALER.**

Any implied warranty of merchantability or fitness for a particular purpose applicable to this vehicle is limited to the duration of the written warranty. Some states do not allow limitations on the time period for an implied warranty, so this limitation may not apply to you.

#### WARRANTY COVERAGE

This warranty covers any repair or replacement of components that fail under normal use due to a defect in materials or workmanship except as set forth under "What Is Not Covered" below. Repairs made under this warranty will be at no cost to you for parts and labor. Repairs will be made using functionally equivalent components as determined by Lexus, including new, used, remanufactured, or rebuilt components. This warranty also provides Complimentary Maintenance, Loaner Car, Towing, Roadside Assistance Protection and Travel Protection coverage as described in the Special Services section of the *Supplement*.

#### WHAT IS NOT COVERED BY THIS WARRANTY REPAIRS COVERED UNDER THE NEW VEHICLE LIMITED WARRANTY

- This Coverage is secondary to the coverage provided by the applicable Lexus New Vehicle Limited Warranty (see your *Owner's Guide* for an explanation of the New Vehicle Limited Warranty).

## L/CERTIFIED BY LEXUS

### WARRANTY

### SUPPLEMENT

## L/CERTIFIED LIMITED WARRANTY

### **EXCLUDED COMPONENTS**

- The following components are specifically excluded from coverage under the L/Certified Limited Warranty.

Accessory Drive Belts; Batteries; Body Panels; Brake Linings, Pads and Shoes, Rotors and Drums; Bumpers; Carpet; Chrome; Clutch Friction Disc and Pressure Plate; Dash Cover and Pad; Door Fabric; Door Trim; Filters; Fluids; Glass (including Windshields); Headliner; Heating Hoses, Lines and Tubes; Hoses; Hybrid Vehicle Battery Pack; Hybrid Vehicle Battery Plug Assembly; Hybrid Vehicle Relay Assembly; Hybrid Vehicle Supply Battery Assembly; Interior and Exterior Trim and Moldings (including but not limited to: Ash Trays, Covers, Cup Holders and Vents); Lamps, Light Assemblies/Housings, and Light Bulbs; Nuts, Bolts, Clips, Retainers, and Fasteners; Paint; Rust and Corrosion Damage; Seat Covers; Sheet Metals; Shiny Metals; Spark Plugs; Structural Framework and Welds; Tires; Vacuum Hoses, Lines and Tubes; Weather Stripping; Wheels and Rims; Windshield Wiper Blades (Rubber Component); All interior and exterior cloth, leather, and stitching including convertible tops and/or vinyl tops including but not limited to: any vibration, deterioration, discoloration, disfigurement, warping, fading, staining, stretching, ripping, punctures, tearing, and/or scratches

### **OTHER ITEMS NOT COVERED**

- Any accessory, whether distributed by Lexus or not, such as wheels, radar detectors, or cellular telephones.
- A non-covered or modified component.
- Any component which has not failed, but which a repair facility recommends or requires to be repaired, replaced, or adjusted.
- Any replacement component consisting of any replacement component that is not a Genuine Lexus component.

### **WARRANTY LIMITATIONS AND EXCLUSIONS**

This warranty covers repairs to covered components. This warranty does not cover any breakdown, mechanical failure or expenses, which are due to, result from, or are caused by any of the following:

### **FACTORS BEYOND THE CONTROL OF LEXUS**

- Abuse, damage by collision, upset or falling objects, larceny or attempted larceny, theft or attempted theft, fire, explosion, or negligence.
- Contamination of fuels, fluids, coolants, or lubricants as well as any resulting rust, corrosion, or other damage.
- Any alteration to your vehicle or any component thereof.

## L/CERTIFIED BY LEXUS

### L/CERTIFIED LIMITED WARRANTY

#### WARRANTY

#### SUPPLEMENT

- Any use of your vehicle not recommended by the manufacturer in your *Owner's Manual, Supplement, and/or Guide*.
- Acts of God, war, riot, insurrection, natural disasters, including but not limited to freezing, extreme heat, windstorms, rainstorms, nuclear contamination, lightning, dust storms, hailstorms, snowstorms, ice storms, earthquakes, or floods.
- Repairs and adjustments required as a result of misuse, negligence, modification, alteration, tampering, disconnecting, improper adjustment, or repairs (unless performed by a Lexus dealership during warranty repair work), accidents, and use of add-on parts.
- Failures caused by modifications or parts not authorized or supplied by the vehicle manufacturer.

#### **PRE-EXISTING CONDITIONS**

- Any conditions that existed prior to date of purchase or lease, damages caused by a previous improper repair, and failures caused by any direct or indirect modifications of parts not authorized or supplied by Lexus.

#### **LACK OF OR IMPROPER MAINTENANCE**

- Repairs and adjustments resulting from improper maintenance, lack of required maintenance, or the use of fluids other than those specified in the *Owner's Manual*. Maintenance is at your expense. Normal maintenance services that all vehicles require include without limitation, oil changes, engine tune-ups,

lubrication, cleaning and polishing, replacement of filters, coolant, spark plugs, fuses, worn wiper blades, brake pads and linings, and clutch linings.

#### **NORMAL NOISE, VIBRATION, AND DETERIORATION**

- Normal noise, vibration, and deterioration such as discoloration, fading, deformation, and normal wear and tear, including but not limited to excessive oil consumption, loss of compression, or a gradual reduction in operating performance due to burned or leaking valves or worn piston rings.

#### **ALTERED MILEAGE**

- This warranty is null and void if the odometer is altered or changed so that the vehicle's mileage cannot be readily determined.

#### **CERTAIN USAGE VOIDS THIS WARRANTY**

- Any use of the vehicle not recommended by the manufacturer in your *Owner's Manual, Supplement and/or Guide* will void this warranty. Also, this warranty is null and void in all respects if the vehicle has been used for certain commercial purposes, including but not limited to: plowing snow, used for hire to public, or to transport people for hire, taxi, shuttle, commuter, municipal, professional, medical, emergency, or police services, competitive driving or racing, or towing a trailer whose weight exceeds Lexus recommendations.

## L/CERTIFIED BY LEXUS

### WARRANTY

### SUPPLEMENT

### L/CERTIFIED LIMITED WARRANTY

#### **OPERATION OF VEHICLE OUTSIDE THE CONTINENTAL UNITED STATES**

- This warranty does not apply during any period in which this vehicle is registered and normally operated outside the continental United States.

#### **SCRAPPED OR SALVAGED VEHICLES**

- Vehicles that have been damaged to such an extent that the owner or the institution financing, leasing, or insuring the vehicle considered it uneconomical to repair it and, as a result, the vehicle was not repaired by or for the person who owned the vehicle at the time of the event resulting in the damage are not covered. This includes but is not limited to those vehicles that are currently or were previously titled as "scrap," "salvage," "repurchase," or "dismantled."

#### **EXTRA EXPENSES AND DAMAGES**

- Lexus does not authorize any person to create for it any other obligation or liability in connection with this vehicle. The performance of repairs and needed adjustments is the exclusive remedy under this warranty or any implied warranty.
- Lexus shall not be liable for incidental or consequential damages (for other than injury to the person) resulting from breach of this written warranty or any implied warranty.

- Some states do not allow the exclusion or limitation of incidental or consequential damages, so the above limitation or exclusion may not apply to you.
- This warranty gives you specific legal rights, and you may also have other rights that vary from state to state.

#### **LIMITS OF LIABILITY**

This warranty shall never exceed either of the following:

#### **OVER THE LIFE OF THIS WARRANTY**

- Your L/Certified Limited Warranty is limited to the fair market value of the vehicle, as determined by Lexus using leading industry used car value guides such as National Automobile Dealers Association ("NADA") Official Used Car Guide or Kelley Blue Book, at the time of purchase.

#### **PER REPAIR VISIT**

- Your L/Certified Limited Warranty is limited to the cost of the covered repair(s) or the fair market value of the vehicle, as determined by Lexus using leading industry used car value guides such as National Automobile Dealers Association ("NADA") Official Used Car Guide or Kelley Blue Book at the time of the repair(s), whichever is less.

## L/CERTIFIED BY LEXUS

### L/CERTIFIED LIMITED WARRANTY

#### WARRANTY

#### SUPPLEMENT

### OWNER'S RESPONSIBILITIES

#### CARE

- In the event of a mechanical failure, immediate action must be taken to protect the vehicle from further damage.
- You are responsible for properly operating and caring for your Lexus vehicle in accordance with the instructions in the *Owner's Manual*. If you drive your vehicle under severe driving conditions, you must follow the applicable maintenance requirements specified in the *Owner's Manual*.
- You are responsible to maintain proper levels of coolants, oils and/or lubricants or proper coolant/water ratio as specified by Lexus in your *Owner's Manual*. Any conditions caused by not maintaining proper levels of coolants, oils and/or lubricants (for example: engine failure due to lack of lubrication or overheating) may invalidate this warranty.

- Your dealer may recommend more frequent intervals than those outlined in your *Owner's Manual* or may include items that are in addition to those in your *Owner's Manual*. These additional services are not required to maintain your warranty coverage. Please see your dealer for an explanation of any maintenance recommendations that are not part of your vehicle's maintenance schedule.
- Warranty service is available only through an authorized Lexus dealer. Your Lexus dealership will make the necessary warranty repairs and adjustments using new or remanufactured parts. Any authorized Lexus dealer will perform warranty service. If your vehicle becomes disabled for any reason or you need to know the closest Lexus dealer to you, please call: **1-800-25-LEXUS (1-800-255-3987)**.

## L/CERTIFIED BY LEXUS

### WARRANTY

### SUPPLEMENT

## PROTECT YOUR LEXUS AGAINST CORROSION

### WHAT YOU CAN DO

Your Lexus vehicle has been specially designed and built to resist corrosion. The exterior sheet metal was formed from Excelite II, which is an antirust sheet steel that is coated with zinc. This steel will provide superb antirust performance. Additionally, your vehicle is equipped with antichip paint and side-protective urethane claddings.

Application of additional rust-inhibiting materials is not necessary to protect your Lexus, nor is it required in order to keep any remaining portion of the six-year warranty coverage provided under the New Vehicle Limited Warranty in effect.

In order to help protect your Lexus vehicle against corrosion, it is important that you care for your vehicle by following these recommendations:

- Wash your vehicle regularly using cold water and a mild vehicle wash soap.
- If insects, tar, or other similar deposits have accumulated on your vehicle, wash it as soon as possible.
- Wash your vehicle in the shade.
- Under certain conditions, special care should be taken to protect your Lexus against corrosion. If you drive on salted or dust-controlled roads, or if you drive near the ocean, hose off the undercarriage at least once a month.
- It is important that the drain holes in the lower edges of the doors and rocker panels be kept clear.
- If you detect any stone chips or scratches in the paint, touch them up immediately. You can have either your Lexus dealer perform the touch-up, or you can perform the touch-up yourself by first contacting your Lexus dealership Parts Specialist to assist you in purchasing touch-up paint.
- If you carry special cargo, such as chemicals, fertilizer, or de-icer materials, be sure that such materials are well packaged and sealed.
- If your Lexus vehicle is damaged due to an accident or similar cause that destroys the paint and protective coating, have your vehicle repaired as soon as possible.

Lexus' corrosion perforation warranty does not cover non-genuine sheet metal parts or damage caused by the installation of such non-genuine sheet metal parts.

L/CERTIFIED BY LEXUS

LEXUS KEY REPLACEMENT

WARRANTY

SUPPLEMENT

Lexus has designed a special vehicle key that incorporates many unique features. As an added security feature, the inner cut grooves of the Lexus key make normal duplication difficult.

To provide a special service to our customers, Lexus has established a system that enables you to have additional keys made. Simply visit your Lexus dealer. An order will be placed for the number of additional keys you require. In most cases, your order should be ready for pickup within five (5) business days.

**Emergency orders (for MASTER keys only) can be placed by calling: 1-800-25-LEXUS (1-800-255-3987)**

If your vehicle is equipped with the remote unlock key feature, replacement keys can be purchased in sets of one, two, or three. Please see the Parts Specialist at your Lexus dealership for assistance.

## L/CERTIFIED BY LEXUS

WARRANTY

SUPPLEMENT

### SAFETY BELT INFORMATION

#### THE EXPERTS SAY, "BUCKLE UP!"

The importance of using seat belts cannot be overemphasized. The safety experts from government and private organizations say, "Buckle Up!" Here are a few good reasons why:

- Properly adjusted seat belts can help reduce driving fatigue and help the driver maintain better vehicle control.
- Studies show that generally the safest place in a collision is inside your vehicle. Seat belts can help keep you there.
- Eight out of ten injury accidents occur at speeds under 40 mph, but even below 5 mph, children can be injured during quick turns or sudden stops. Children who are too small to wear regular seat belts should always be provided with a Child Restraint System dynamically tested to meet federal standards.

In addition to seat belts, every Lexus vehicle is equipped with a driver's side\* restraint system (SRS airbag). Airbags have been designed to supplement the three-point seat belt by providing additional protection by restraining the driver's forward motion in the event of a more serious frontal accident. **The SRS does not replace use of the seat belt.** To obtain maximum protection in an accident, the driver and all passengers in the vehicle should always wear their seat belts.

#### GET THAT GOOD FEELING

Familiarize yourself with the operation of your seat belts, as explained in your *Owner's Manual*. Wear them every time you drive your Lexus, and encourage those who ride with you to do the same.

Remember: For peace of mind, buckle up...it's a good feeling!

\* Some Lexus models are equipped with a passenger-side supplemental restraint system. See your *Owner's Manual* for details.



## L/CERTIFIED BY LEXUS

### ROADSIDE ASSISTANCE PROTECTION

WARRANTY

SUPPLEMENT

#### HOW TO GET HELP

To obtain emergency Roadside Assistance, simply perform the following procedures:

1. Call 1-800-25-LEXUS (1-800-255-3987)
2. Have as much of the following information as possible available to expedite the dispatch process:
  - Vehicle Identification Number (This consists of 17 digits and can be found on the lower front corner of the dashboard on the driver's side and on a sticker on the driver's side door post.)
  - Owner's Name and Address
  - Vehicle License Plate Number

3. The dispatch operator will ask you to provide the area code and first three digits of the telephone number from which you are calling to determine your location.
4. After determining the specific location of your vehicle and the services requested, the dispatch operator will keep you on the line while arranging for a local roadside service provider to respond to your call.
5. The dispatch operator will then come back to the line and provide you with an estimated time of arrival.
6. The local roadside service agency will then provide the necessary assistance.

ROADSIDE ASSISTANCE  
PROTECTION

## L/CERTIFIED BY LEXUS

### WARRANTY

### SUPPLEMENT

## ROADSIDE ASSISTANCE PROTECTION

Everything about Lexus reflects the uncompromising attitude with which it was developed. This devotion extends beyond the remarkable Lexus vehicles to a genuine concern for the comfort and safety of Lexus owners.

As a Lexus owner, you are as uncompromising as the vehicle you drive. Lexus Roadside Assistance was developed specifically to meet your expectations anytime, virtually anywhere, with a national network of roadside service providers. If you should find yourself in need of Roadside Assistance, just call. Lexus will take care of the details.

*Lexus owners\* are automatically protected by Roadside Assistance with emergency service 24 hours a day, 365 days per year for two years from the expiration of the Basic Warranty or from the vehicle purchase date, whichever occurs later. Mileage is unlimited.*

\* Applicable to the registered certified owner only. This certified warranty and its benefits are nontransferable.

### YOUR CONSTANT TRAVEL COMPANION

Across the continental U.S. and Canada, Lexus provides:

- Roadside services such as flat tire, lockout, jump start and emergency fuel delivery (up to 3 gallons).
- Unlimited towing to the nearest Lexus dealership.
- Assistance in locating substitute transportation and lodging.
- A travel protection guarantee (for warrantable repairs) that covers substitute transportation and lodging and meal expense reimbursement. Please see the Special Services section on page 6 for terms, conditions, and restrictions.
- And, as a further service to Lexus owners, at the end of your two-year Roadside Assistance coverage, you will be invited to purchase membership in a special motor club for Lexus Owners. Roadside Assistance coverage, trip planning and hotel and travel discounts are just a sampling of the special benefits that are available.

# L/CERTIFIED BY LEXUS

## NATIONAL SERVICE HISTORY DATABASE

### WARRANTY

### SUPPLEMENT

As a Lexus owner you will be able to visit any Lexus dealer in the continental U.S. for service, knowing your vehicle's Lexus-performed service history is available at that dealership.

This has been made possible through Lexus' establishment of the first National Service History database in the automotive industry.

Whenever you have your Lexus serviced at an authorized Lexus dealership located in the continental U.S., your servicing information is automatically transmitted to our central National Service History database. Once this information is in our system, it is readily accessible to any Lexus dealership.

If you move or are traveling, any Lexus dealership will have access to your vehicle's service history. When you decide to either sell or trade in your current Lexus for a newer model, your vehicle's service history can be obtained and presented along with your vehicle as confirmation of the excellent condition in which it was kept.

# L/CERTIFIED BY LEXUS

WARRANTY

## SERVICE MAINTENANCE RECORD

SUPPLEMENT

_____	_____	_____	_____
<i>Model</i>	<i>Year</i>	<i>Vehicle Identification Number</i>	<i>In-Service Date</i>
_____	_____	_____	_____
<i>Engine Number</i>	<i>Name of Owner</i>	<i>License Plate Number</i>	
_____	_____	_____	_____
<i>Address of Owner</i>		<i>Telephone/Business</i>	
_____		_____	_____
		<i>Telephone/Home</i>	

**COMPLIMENTARY MAINTENANCE** begins the day you purchase or lease your vehicle and covers factory recommended maintenance services that occur during the time your coverage is active for 2 years or 20,000 miles, whichever comes first. Service intervals occur every 5,000 miles or every 6 months, whichever occurs first.

L/CERTIFIED BY LEXUS

SERVICE MAINTENANCE RECORD

WARRANTY

SUPPLEMENT

**COMPLIMENTARY MAINTENANCE ONE**

Miles

Performed by (Dealer Stamp)

**NO CHARGE**

Date Mileage

Dealer Authorized Signature

**COMPLIMENTARY MAINTENANCE TWO**

Miles

Performed by (Dealer Stamp)

**NO CHARGE**

Date Mileage

Dealer Authorized Signature

**COMPLIMENTARY MAINTENANCE THREE**

Miles

Performed by (Dealer Stamp)

**NO CHARGE**

Date Mileage

Dealer Authorized Signature

**COMPLIMENTARY MAINTENANCE FOUR**

Miles

Performed by (Dealer Stamp)

**NO CHARGE**

Date Mileage

Dealer Authorized Signature

# L/CERTIFIED BY LEXUS

WARRANTY

## SERVICE MAINTENANCE RECORD

SUPPLEMENT

*Performed by (Dealer Stamp)*

*Performed by (Dealer Stamp)*

*Performed by (Dealer Stamp)*

Date Mileage

Date Mileage

Date Mileage

Dealer Authorized Signature

Dealer Authorized Signature

Dealer Authorized Signature

*Performed by (Dealer Stamp)*

*Performed by (Dealer Stamp)*

*Performed by (Dealer Stamp)*

Date Mileage

Date Mileage

Date Mileage

Dealer Authorized Signature

Dealer Authorized Signature

Dealer Authorized Signature

L/CERTIFIED BY LEXUS

SERVICE MAINTENANCE RECORD

WARRANTY

SUPPLEMENT

[Empty box for service description]

Performed by (Dealer Stamp)

Date Mileage

Dealer Authorized Signature

[Empty box for service description]

Performed by (Dealer Stamp)

Date Mileage

Dealer Authorized Signature

[Empty box for service description]

Performed by (Dealer Stamp)

Date Mileage

Dealer Authorized Signature

[Empty box for service description]

Performed by (Dealer Stamp)

Date Mileage

Dealer Authorized Signature

[Empty box for service description]

Performed by (Dealer Stamp)

Date Mileage

Dealer Authorized Signature

[Empty box for service description]

Performed by (Dealer Stamp)

Date Mileage

Dealer Authorized Signature

# L/CERTIFIED BY LEXUS

WARRANTY

## SERVICE MAINTENANCE RECORD

SUPPLEMENT

*Performed by (Dealer Stamp)*

*Performed by (Dealer Stamp)*

*Performed by (Dealer Stamp)*

Date Mileage

Date Mileage

Date Mileage

Dealer Authorized Signature

Dealer Authorized Signature

Dealer Authorized Signature

*Performed by (Dealer Stamp)*

*Performed by (Dealer Stamp)*

*Performed by (Dealer Stamp)*

Date Mileage

Date Mileage

Date Mileage

Dealer Authorized Signature

Dealer Authorized Signature

Dealer Authorized Signature



L/CERTIFIED BY LEXUS

SERVICE MAINTENANCE RECORD

WARRANTY

SUPPLEMENT

[Empty box for service description]

Performed by (Dealer Stamp)

Date Mileage

Dealer Authorized Signature

[Empty box for service description]

Performed by (Dealer Stamp)

Date Mileage

Dealer Authorized Signature

[Empty box for service description]

Performed by (Dealer Stamp)

Date Mileage

Dealer Authorized Signature

[Empty box for service description]

Performed by (Dealer Stamp)

Date Mileage

Dealer Authorized Signature

[Empty box for service description]

Performed by (Dealer Stamp)

Date Mileage

Dealer Authorized Signature

[Empty box for service description]

Performed by (Dealer Stamp)

Date Mileage

Dealer Authorized Signature

# L/CERTIFIED BY LEXUS

WARRANTY

## SERVICE MAINTENANCE RECORD

SUPPLEMENT

*Performed by (Dealer Stamp)*

*Performed by (Dealer Stamp)*

*Performed by (Dealer Stamp)*

Date Mileage

Date Mileage

Date Mileage

Dealer Authorized Signature

Dealer Authorized Signature

Dealer Authorized Signature

*Performed by (Dealer Stamp)*

*Performed by (Dealer Stamp)*

*Performed by (Dealer Stamp)*

Date Mileage

Date Mileage

Date Mileage

Dealer Authorized Signature

Dealer Authorized Signature

Dealer Authorized Signature

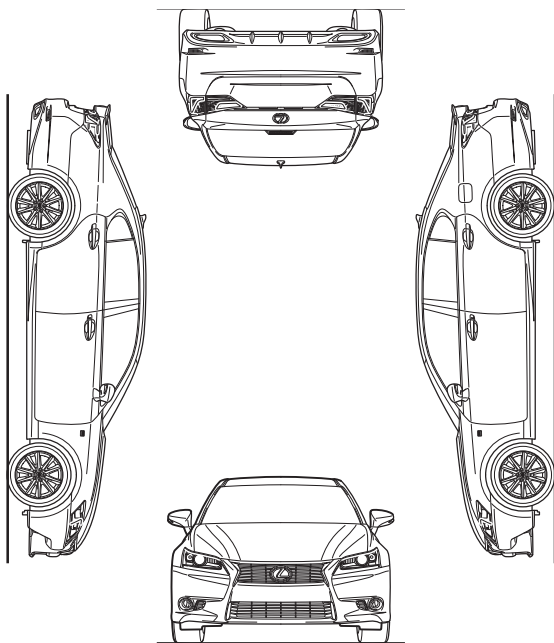

Body inspection performed as part of scheduled maintenance.

## ANNUAL BODY INSPECTION

\_\_\_\_\_  
To be completed by technician during major yearly maintenance/inspection.  
Indicate by (X) where attention needed.

### INSPECTION PERFORMED DURING

\_\_\_\_\_  
*Mile Maintenance*

\_\_\_\_\_  
*Date*

Performed by (Dealer Stamp)

\_\_\_\_\_  
*Dealer Authorized Signature*

# L/CERTIFIED BY LEXUS

WARRANTY

SUPPLEMENT

## BODY INSPECTION

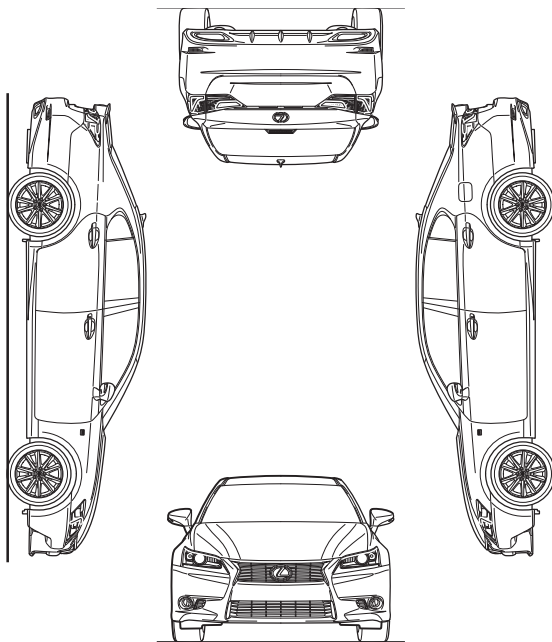

Body inspection performed as part of scheduled maintenance.

## ANNUAL BODY INSPECTION

To be completed by technician during major yearly maintenance/inspection. Indicate by (X) where attention needed.

### INSPECTION PERFORMED DURING

Mile Maintenance

Date

Performed by (Dealer Stamp)

Dealer Authorized Signature

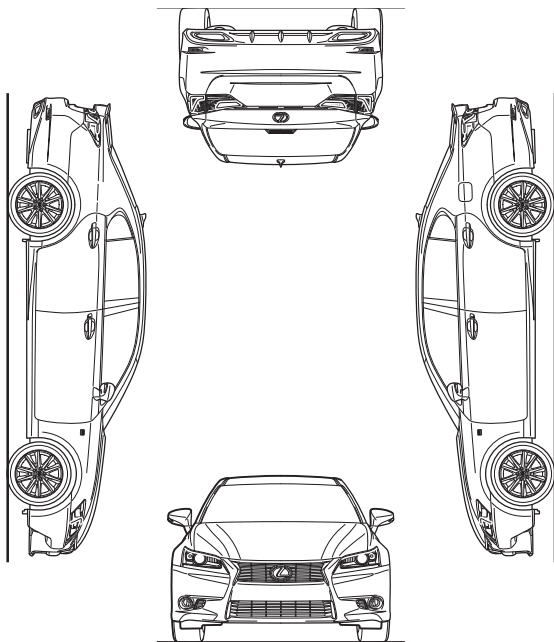

Body inspection performed as part of scheduled maintenance.

## ANNUAL BODY INSPECTION

\_\_\_\_\_

To be completed by technician during major yearly maintenance/inspection.  
Indicate by (X) where attention needed.

### INSPECTION PERFORMED DURING

\_\_\_\_\_

*Mile Maintenance*

\_\_\_\_\_

*Date*

Performed by (Dealer Stamp)

\_\_\_\_\_

*Dealer Authorized Signature*

# L/CERTIFIED BY LEXUS

WARRANTY

SUPPLEMENT

## BODY INSPECTION

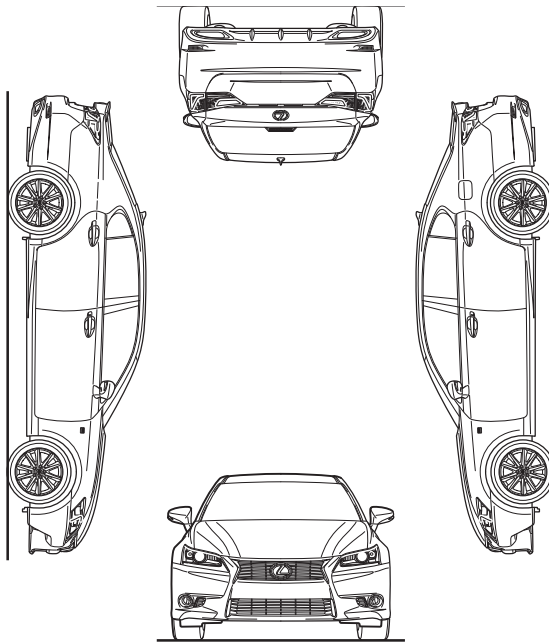

Body inspection performed as part of scheduled maintenance.

## ANNUAL BODY INSPECTION

\_\_\_\_\_  
To be completed by technician during major yearly maintenance/inspection.  
Indicate by (X) where attention needed.

### INSPECTION PERFORMED DURING

\_\_\_\_\_  
*Mile Maintenance*

\_\_\_\_\_  
*Date*

Performed by (Dealer Stamp)

\_\_\_\_\_  
*Dealer Authorized Signature*

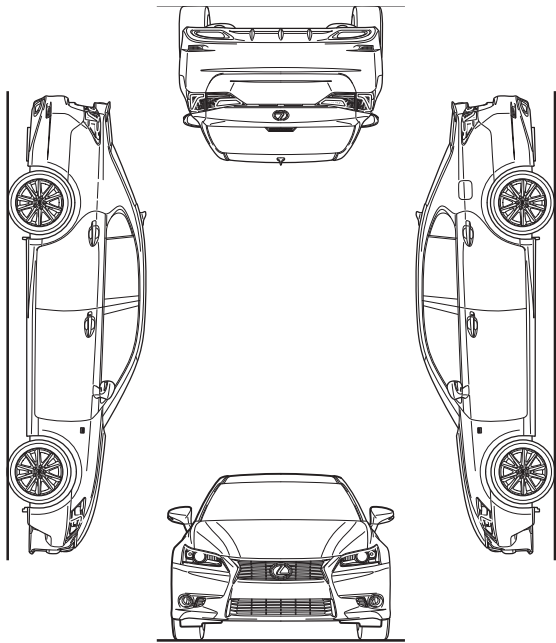

Body inspection performed as part of scheduled maintenance.

# ANNUAL BODY INSPECTION

\_\_\_\_\_

To be completed by technician during major yearly maintenance/inspection. Indicate by (X) where attention needed.

### INSPECTION PERFORMED DURING

\_\_\_\_\_  
*Mile Maintenance*

\_\_\_\_\_  
*Date*

<i>Performed by (Dealer Stamp)</i>
------------------------------------

\_\_\_\_\_  
*Dealer Authorized Signature*

# L/CERTIFIED BY LEXUS

WARRANTY

SUPPLEMENT

## BODY INSPECTION

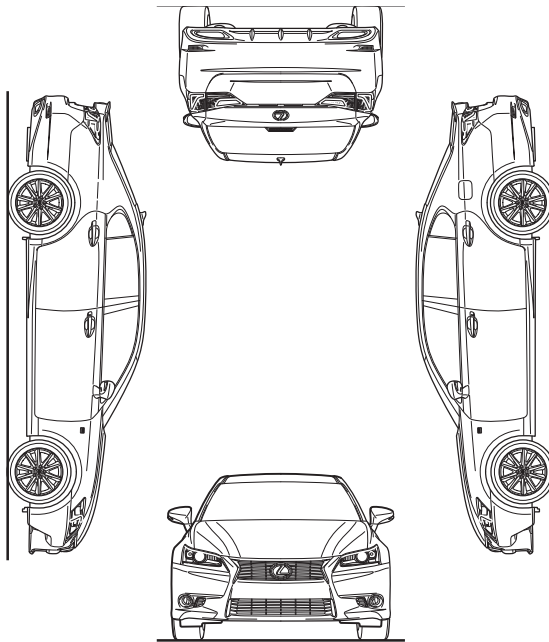

Body inspection performed as part of scheduled maintenance.

## ANNUAL BODY INSPECTION

To be completed by technician during major yearly maintenance/inspection. Indicate by (X) where attention needed.

### INSPECTION PERFORMED DURING

Mile Maintenance

Date

Performed by (Dealer Stamp)

Dealer Authorized Signature









